



Babcock Wanson UK
ENIM Group

Energy made to Measure

Babcock Wanson LNHI COMBI Thermal Oxidising Incinerator and Combined Thermal Fluid Heater



LNHI COMBI

- The long experience of Babcock Wanson in the technologies of gaseous effluent incineration and thermal fluid heat transfer are brought together in the Babcock Wanson LNHI COMBI Series, enabling a compact fully integrated system to be built into a process plant with ease of installation and minimum plant room space.
- The Babcock Wanson LNHI COMBI offers a simple solution to ensure environmental emission compliance with high efficiency energy production for a wide range of food, chemical and other industrial processes.



Why Thermal Oxidisation?

Emissions to atmosphere of odours, Volatile Organic Compounds (VOCs) and nuisance vapours are increasingly encompassed within environmental laws. The LNHI COMBI is designed to solve these problems.

Why Thermal Fluid?

Heat recovered from the Thermal Oxidising process is available for use in the production process. The most effective method is by using a thermal fluid. This system offers the following:

- Closed circuit – No loss – Low cost
- Low pressure – High temperature
- Corrosion free – No freezing hazard
- Precise temperature control providing best quality client product
- Compatible food grade fluids if required
- No effluent produced – No water treatment etc.
- Low maintenance – Long plant life
- Well proven technology

Why Babcock Wanson?

- Expertise – wide client process knowledge
- Turnkey or design and supply
- Experience – 70 years of combustion process and thermal fluid system design
- Research based designs
- Products approved by leading inspection authorities: BV, DNV, Lloyds, APAVE etc, as required
- Oil, gas or dual support fuel options
- After Sales Service network with full client support provided by our extensive team of qualified and experienced engineers
- Worldwide capability and back-up contract maintenance options tailored to your needs
- Life-time supplier/client partnership to take advantage of technology developments and performance enhancements



Cont. No. FM 25956



Babcock Wanson as world leaders in thermal fluid heater and incineration system designs offer:

- Solutions for process heating and gaseous effluent destruction implemented by our own competent Design Project and Contract Engineers in a wide range of industries including plastics, metal finishing, chemical and food processing.
- **Burners** – Standard package burners are fitted in either light oil, natural gas or dual fuel configuration fully integrated into the LNHI COMBI control system for safe automatic operation. High efficiency low Nox design ensures emission figures well within European Standard limits.
- **Control** – Each LNHI COMBI system is provided with a comprehensive control system within the integrated control cabinet. Temperatures are continuously monitored for optimum heat conditions within the system for the heat user. Burner management controls and heater safety systems are also mounted within the cabinet.
- **Thermal Fluid Pump** – The pumps provided by Babcock Wanson are carefully selected to ensure that the flow requirements of both heater and system are met in accordance with the application design and temperature specifications.

BABCOCK WANSON LNHI COMBI SERIES

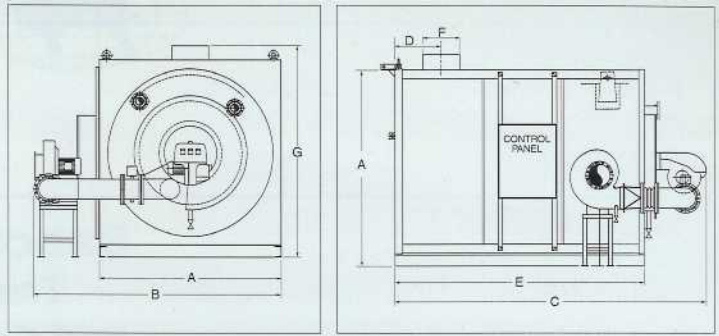

DIMENSIONS (mm)

Data and dimensions approximate only

Model Number	650	850	1250	1650	2050
A	1560	1570	1910	2472	2644
B	2010	2020	2350	2921	3092
C	3080	3580	4020	4500	4900
D	490	540	600	630	630
E	2240	2740	3030	3400	3700
F	299	349	424	499	499

TECHNICAL DATA

Model Number	650	850	1250	1650	2050
Burner Motor kW	1.5	2.2	4.0	7.5	7.5
Min Rec. Chimney Dia. mm	356	356	453	508	600
Operating Weight in Operation kg	4600	5800	8600	13000	13500
Fluid Content l	519	723	1297	2348	2147
Nominal Inlet Effluent Flow m ³ /h @ 100°C	700	830	1700	3000	3780
Primary recovery to Thermal Fluid kW	180	215	440	775	975
Opt. secondary recovery to Hot Water kW	25	30	60	105	130

TYPICAL BABCOCK WANSON LNHI COMBI INTEGRATED SYSTEM WITH THERMAL FLUID

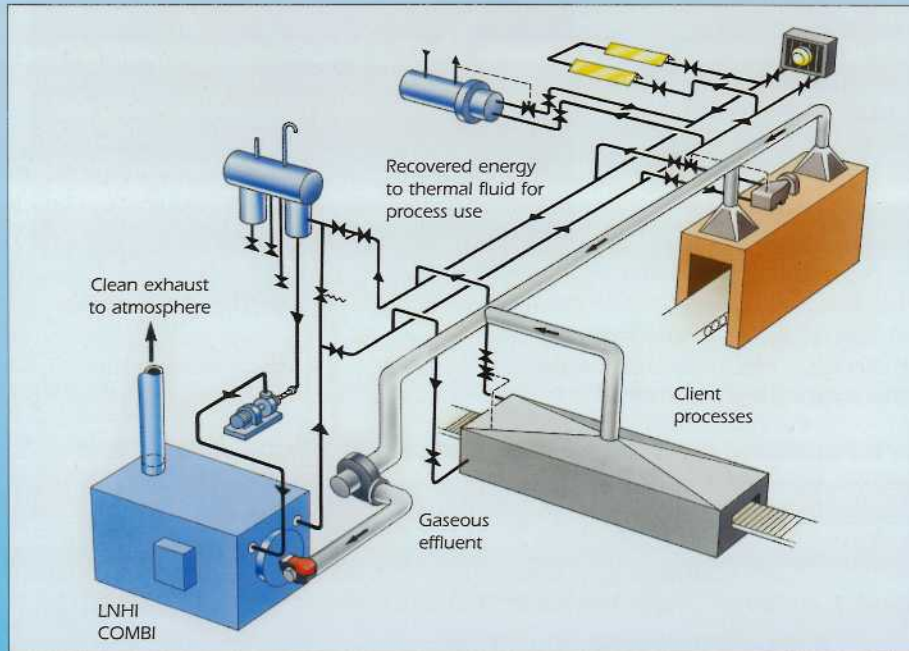

Fuel consumption will vary from process to process dependant on the combustible elements in the effluent gas.

For a Model 1250 LNHI COMBI, typical fuel consumption would be between 40 and 50kg/h of gas oil or between 50 and 60 m³/h of natural gas (G20) for a moderate calorific value effluent.

After Sales Service – All parts of the LNHI COMBI product are replaceable and upgradeable and Babcock Wanson UK maintains a well-stocked parts store. In addition to a full commissioning service our Service Division, staffed with fully trained, qualified and approved engineers (CORGI approved), is able to offer on call as well as planned service and maintenance contracts wherever you are and whenever required.

**“115 years of Babcock – 70 years of Wanson – 42 years of Wanson UK.
There is no substitute for experience.”**



Babcock Wanson UK
ENIM Group

Babcock Wanson UK Ltd 7 Elstree Way, Borehamwood, Hertfordshire WD6 1SA, UK

Tel: 020 8953 7111 Fax: 020 8207 5177 Email: wanson@babcock-wanson.co.uk

Sales and Manufacturing facilities in UK, Belgium, France, Italy, Morocco, Poland, Portugal, Spain and Switzerland.

The Babcock Wanson Organisation operates in more than 50 countries. This network makes it possible to offer services to Babcock Wanson customers anywhere in the world. Babcock Wanson Company's policy is one of continuous improvement and the right is reserved to change specifications and dimensions at any time without notice.